



NEW!

ENGINE

Make	: DEUTZ TCD 4.1 L4
Type	: High power and torque output, water cooled, turbocharged diesel engine.
Number of Cylinders	: 4 in line
Bore & Stroke	: 101 mm x 126 mm
Displacement	: 4.100 cc
Maximum Power	: 169 HP (115 kW) @2200 rpm
Maximum Torque	: 699 Nm @1500 rpm
Emission Class	: EU Stage V

ELECTRICAL SYSTEM

Voltage	: 24 V
Battery	: 2 x 12 V 105 Ah
Alternator	: 28 V / 80 A
Starting Motor	: 24 V / 4 kW

STEERING SYSTEM

Oscillation angle	: ± 12°
Articulation angle	: ± 35°

CAPACITY

Fuel tank	: 350 L
Hydraulic tank	: 105 L

TIRES

23.1-26 12 PR	
---------------	--

VIBRATION

Vibration frequency, for high amplitude/for low amplitude	: 27,5 / 30 Hz
Amplitude, high/low	: 1,95 / 0,81 mm
Centrifugal force, for high amplitude/for low amplitude	: 210 / 104 kN

DRIVING SPEED

Maximum slope with vibration / without vibration	% 42 / % 45
1 st gear	: 5 km/h
2 nd gear	: 6 km/h
3 rd gear	: 9 km/h
4 th gear	: 12 km/h

STANDARD EQUIPMENTS

- Smooth drum
- Double front and rear steel scraper
- HVAC
- FOPS level-2 and ROPS cabin
- Automatic vibration
- Tactile 8" color display (with cabin)
- Audio center with mp3/Usb/aux
- Speed indication in display
- Service interval check in Display
- Tablet PC and phone holder
- Glass holder
- LED interior light
- Sun-visors
- 12 V auxiliary socket
- Swivel and sliding seat
- Seat warning sensor
- Seat with safety belt
- Storage pockets
- Working lights (halogen)
- Rotary beacon (halogen)
- Tilt and Adjustable steering column
- Storage boxes for operator
- Pool type mat
- Monoblock Engine hood with electric actuator
- 4 travelling
- Limited-slip axle
- 2 vibration ranges
- Reverse alarm & 2 warning horns
- Easy accessible Hyd. test ports
- Tools kit
- One key system

OPTIONAL EQUIPMENTS

- Plastic Scrapers
- Rear camera
- Inclinometer
- Compactimeter
- Smartlink
- Circulation lighting (Rear)
- Padfoot

WEIGHT

Standard machine operating weight	: 11.150 kg
Drum (front axle load)	: 6.300 kg
Wheels (rear axle load)	: 4.850 kg
Static linear load	: 29,6 kg/cm

Operational weight, complying with the EN500-1 standards, includes half fuel tank, hydraulic system and other liquids, 75 kg operator weight and standard equipped machine weight. Optional equipments are not included.

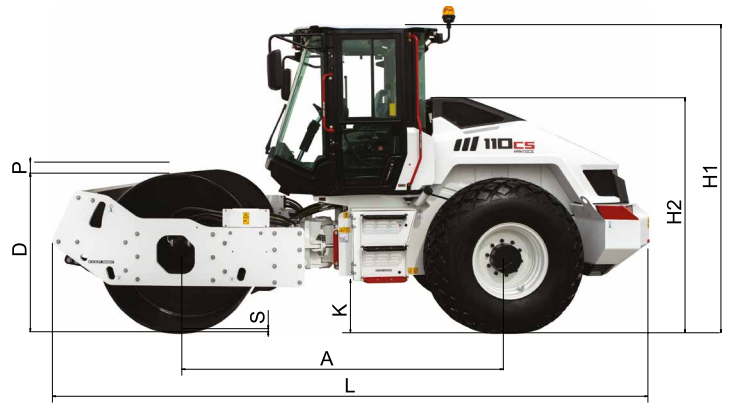

DIMENSIONS

A	Wheelbase	3.065 mm
L	Length (standard equipment), Maximum	5.850 mm
H1	Height (with ROPS cabin), Maximum	2.970 mm
H2	Height without cabin (expedition)	2.280 mm
D	Diameter, drum	1.500 mm
S	Shell thickness, drum	25 mm
W	Width, drum	2.130 mm
P	Height, pads (option)	100 mm
K	Ground clearance, tractor frame	470 mm
B	Width (standard equipped), Maximum	2.280 mm
A1	Turning angle	± 35°
O1	Lateral overhang, right	70 mm
O2	Lateral overhang, left	80 mm
R	Turning radius, inside	3.715 mm

