

NEW!

ENGINE

Model	: ISUZU-6HK1X
Type	: Water-cooled, 4 cycle, 6 cylinders, line type direct injection, turbocharger, intercooler, electronic diesel engine
Power	: 264 HP (197 kW) @1800 rpm / SAE J1995 (Gross) : 207 HP (154 kW) @1800 rpm / SAE J1995 (Net)
Max. Torque	: 1050 Nm @1500 rpm (Gross) : 903 Nm @1500 rpm (Net)
Displacement	: 7790 cc
Bore and Stroke	: 115 mm x 125 mm
Emission Class	: Stage V-EU

SUB-FRAME

X Type Lower Frame Construction Pentagon Box Type Chassis	
Shoe	: Triple grouser
No. Of Shoes	: 2 x 51
No. Of Lower Rollers	: 2 x 9
No. Of Upper Rollers	: 2 x 2
Full Trackguard	: 2 x 3
Track Tensioning	: Hydraulic Spring Tensioning

CAB

- Improved operator's all round visibility
- Increased cabin internal space
- Use of six viscomount cabin mountings that dampen the vibrations
- High capacity A/C
- High resolution, led backlight, color LCD display
- Opera Control System
- Cooled storage room
- Glass holder, book and object storage pockets
- Pool type floor mat
- Improved operator's comfort through versatile adjustable seat
- Ergonomically redesigned cabin through relocated switch board, and re-styled travel pedals and joysticks.

TRAVEL AND BRAKES

Travel	: Fully hydrostatic
Travel Motor	: Axial piston motor with 2 speed stages and inclined plate
Reduction	: Planetary gear system with 2 stages
Travel Speed	
High Speed	: 5,1 km/h
Low Speed	: 3,0 km/h
Max Traction	: 25.460 kgf
Gradeability	: 35° (70%)
Parking Brake	: Hydraulic, disc type with automatic warning
Ground pressure (600mm)	: 0,61 kgf/cm ²

LUBRICATION

Centralized lubrication system is provided for lubrication all difficult-to-reach parts on the components, such as boom and arm

HYDRAULIC SYSTEM

Main Pump	
Type	: 2 axial piston type pumps with doublevariable displacement and inclined plate
Max. Flow Rate	: 2 x 266 L/min
Pilot Pump	: Gear type, 30,5 L/min
Working Pressures	
Cylinders	: 350 kgf/cm ²
Power Boost	: 380 kgf/cm ²
Travel	: 350 kgf/cm ²
Swing	: 285 kgf/cm ²
Pilot	: 40 kgf/cm ²
Cylinders	
Boom	: 2 x ø 135 x ø 95 x 1.455 mm
Arm	: 1 x ø 150 x ø 105 x 1.760 mm
Bucket	: 1 x ø 135 x ø 95 x 1.195 mm

OPERA CONTROL SYSTEM

- Easy-to-use control panel and menu
- Improved fuel economy and productivity
- Selection of multi-language on control panel
- Automatic powerboost switch-on and switch-off
- Overheat prevention and protection system without interrupting the work
- Automatic electric cut-off
- Maintenance information and warning system
- Error mode registry and warning system
- GPRS satellite tracking system (Optional)
- Automatic preheater
- Auto-Idle and automatic deceleration system
- Automatic powershift to improve performance
- Maximum efficiency by selection of power and work modes
- Real time monitoring of operational parameters such as pressure, temperature, engine load
- Anti-theft system with personal code
- Possibility to register 27 different operating hours
- Rear-view, arm-view camera (Optional)

SWING SYSTEM

Swing Motor	: Axial piston type integrated with shock absorber valves
Reduction	: 2 stage planetary gear box.
Swing Brakes	: Hydraulic multi disc type, automatic warnings
Swing Speed	: 10,10 rpm

CAPACITY

Fuel Tank	: 475 L	Radiator	: 55 L
Hydraulic Tank	: 210 L	Engine Oil	: 37 L
Hydraulic System	: 395 L		

ELECTRICAL SYSTEM

Voltage	: 24 V
Battery	: 2 x 12 V x 150 Ah
Alternator	: 24 V / 50 A
Starting Motor	: 24 V / 5 kw

WEIGHT

Standard machine operating weight	: 35.000 kg
-----------------------------------	-------------

Operational weight, complying with the ISO 6016 standards, includes full fuel tank, hydraulic system and other liquids, 75 kg operator weight and standard equipped machine weight. Optional equipments are not included.

HMK310LCLR H4

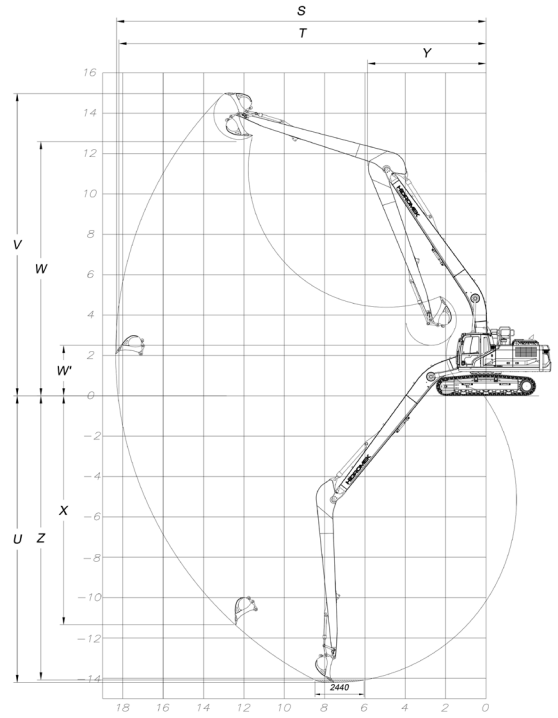
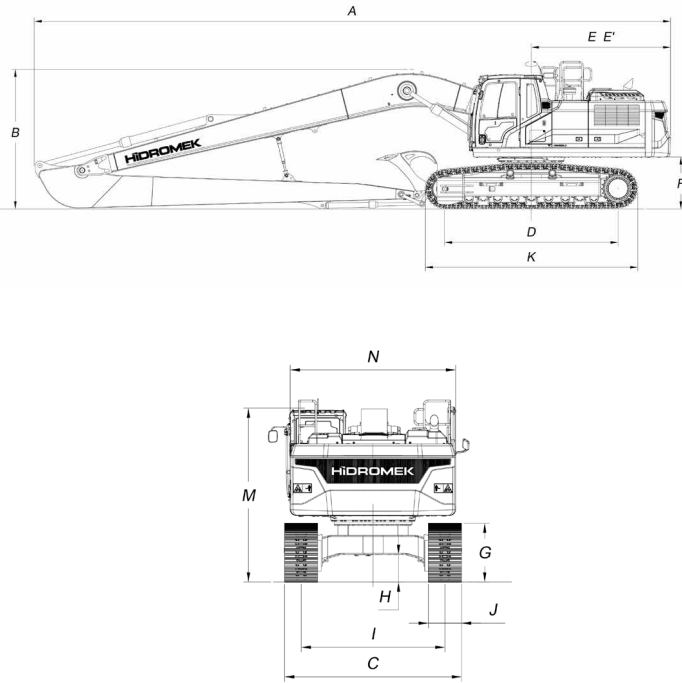

GENERAL DIMENSIONS

Boom Dimension	10.300 mm
Arm Dimension	7.800 mm
A - Overall Length	14.800 mm
B - Overall Height (to top of boom)	3.270 mm
C - Overall Width	3.200 mm
D - Idler Distance	4.030 mm
E - Counterweight Distance	3.240 mm
E' - Turning Radius	3.295 mm
F - Upper Structure Ground Clearance	1.200 mm
G - Crawler Height	1.065 mm
H - Minimum Ground Clearance	505 mm
I - Track Gauge	2.600 mm
J - Shoe Width	800 mm
K - Overall Length of Crawler	4.940 mm
L - Length Over Ground	4.820 mm
M - Overall Height (to Top of Cab)	3.125 mm
N - Upper Structure Width	3.000 mm

WORKING DIMENSIONS

Boom Dimension	10.300 mm
Arm Dimension	7.800 mm
S - Maximum Digging Reach	18.360 mm
T - Maximum Digging Reach at Ground Level	18.240 mm
U - Maximum Digging Depth	14.250 mm
V - Maximum Digging Height	14.920 mm
W - Maximum Dumping Clearance	12.550 mm
W' - Minimum Dumping Clearance	2.500 mm
X - Maximum Vertical Digging Depth	12.570 mm
Y - Minimum Swing Radius	5.930 mm
Z - Maximum Digging Depth (2440 mm level)	14.140 mm

DIGGING PERFORMANCE

Standard Bucket Capacity (SAE)	0,6 m ³
Bucket Digging Force (Power Boost) ISO	6.600 kgf
Arm Crowd Force (Power Boost) ISO	4.800 kgf

* Standard



HIDROMEK®

FACTORY - HEAD OFFICE
 Ahi Evran OSB Mahallesi Osmanlı Caddesi No:1 06935 Sincan / ANKARA / TURKEY
 Tel: (+90) 312 267 12 60 Fax: (+90) 312 267 12 39
www.hidromek.com

Notice:
 Hidromek has the right to modify the specifications and design of the model indicated on this brochure without prior notice.